

TRICON PVC PIPE SYSTEM

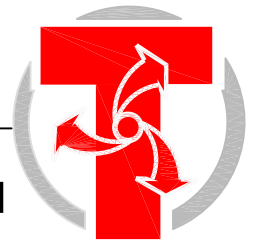

For Applications Up To 40°-75° F Below And Above Ground

- Chilled Water
- Condenser Water
- Potable Water
- Process Piping
- Waste Water

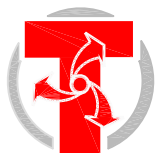
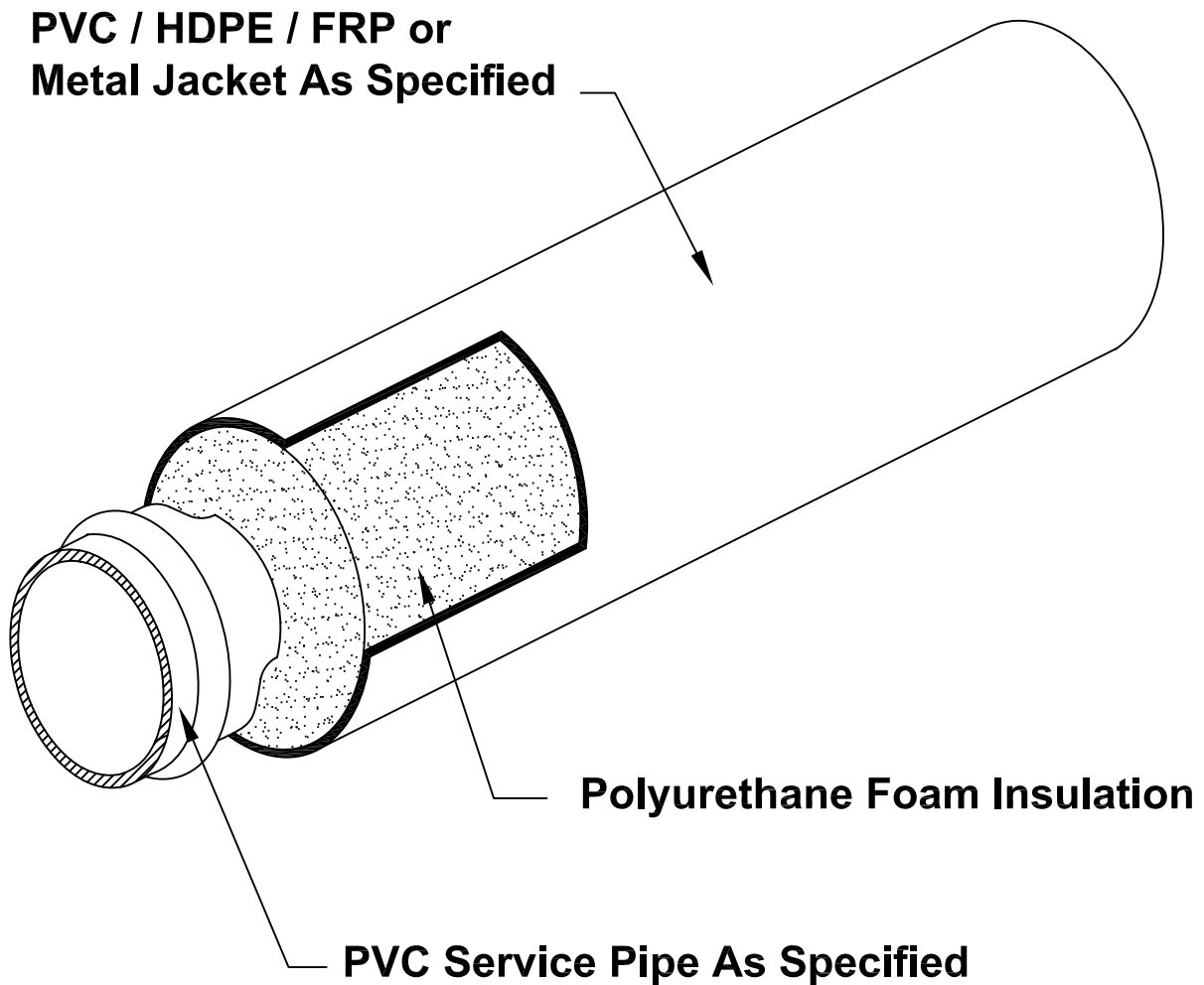

TRICON
Piping Systems, Inc.®

P.O. Box 361, Canastota, New York 13032
Tel: 315.697.8787 Fax: 315.697.8788

TABLE 1

Pipe Size	Minimum Insulation Thickness	PVC Jacket O.D.	PVC Jacket Wall
2"	1.81"	6.14"	.070"
3"	1.25"	6.14"	.070"
4"	1.75"	8.16"	.080"
6"	1.69"	10.20"	.100"
8"	1.69"	12.24"	.120"
10"	1.65"	14.32"	.140"
12"	1.47"	16.00"	.160"

Service Pipe:

PVC SDR-26, Class 160, bell and spigot, gasket joint pipe per ASTM D-2241 and D-1784 supplied in nominal 20 Ft. lengths. Pipe is rated for 160 psi @73°F.

Alternate Service Pipe #1: PVC SDR-21, Class 200, bell and spigot, gasket joint pipe per ASTM D-2241 and D-1784 supplied in nominal 20 Ft. lengths. Pipe is rated for 200 psi @73°F.

Alternate Service Pipe #2: PVC SDR-35, Sanitary Sewer & Storm Drainage, bell and spigot, gasket joint pipe per ASTM D-3034 and D-1784 supplied in nominal 14 Ft. lengths. Pipe is not rated for pressure.

Alternate Service Pipe #3: SCH. 40, / Sch. 80 solvent weld joint. Supplied in nominal 20 Ft. lengths.

Insulation:

The insulation shall be a foamed in place closed cell polyurethane which completely fills the annular space between the carrier pipe and the exterior casing. The insulation shall have the following physical properties:
 Minimum Density (lb./cu. ft.) 2.0 ASTM D-1621
 90-95 % Closed Cell ASTM D-2856
 "K" Factor BTU/Hr. sq. ft. °F/in. .147 ASTM C-177

Exterior Casing:*

The exterior casing shall be
 (1) Seamless, extruded white PVC Type 1, Grade 1, and Class 12454-B per ASTM D-1784 **or**
 (2) High Density Polyethylene ASTM D-1248 (H.D.P.E.) with the following physical properties.
 ASTM D-3350.....Resin Type III, Grade P34
 ASTM D-633.....Tensile Yield Strength 3300 psi
 ASTM D-633.....Ultimate Elongation 850%
 ASTM D-790...Tangent Flexural Modules 175,000 psi
No polyethylene tape casings will be allowed.

Fittings:

All fittings below 10" shall be PVC with a gasket joint. Fittings greater than 10" may be Ductile Iron. Fittings are to remain un-insulated and poured in a concrete thrust block. Concrete thrust block design is dependant upon soil conditions, size of pipe and force due to thermal stress. Design and sizing of anchor blocks remains the responsibility of the design engineer.

TABLE 2

Pipe Size	Minimum Insulation Thickness	HDPE Jacket O.D.	HDPE Jacket Wall
2"	2.00"	6.63"	.150"
3"	1.43"	6.63"	.150"
4"	1.58"	8.00"	.150"
6"	1.51"	10.00"	.175"
8"	1.69"	12.43"	.175"
10"	1.48"	14.06"	.175"
12"	1.39"	15.87"	.175"

Field Joints:

Field Joints for underground applications of gasketed joint pipe are to remain un-insulated to allow for expansion and contraction. Joints may be covered to keep out debris or moisture with an oversized sleeve and sealed with tape or heat shrink sleeve. Insulation at ends of pipe to be sealed with mastic or heat shrinkable end seal.

Installation:

No Piping shall be installed in standing water. Trenches shall be maintained dry until backfilling is complete.

The installing contractor shall handle the piping system in accordance with the directions furnished by the manufacturer and as approved by the architect and engineer. The carrier piping shall be hydrostatically tested as specified in the contract documents. **Each unit length must be partially backfilled prior to hydro testing.**

EXERCISE DUE CARE WHEN INSTALLING AND TESTING THE PIPING SYSTEM.

DO NOT TEST WITH AIR OR GAS.

Backfill:

A 4-inch layer of sand or fine gravel, less than ½" in diameter, shall be placed and tamped in the trench to provide uniform bedding for the PVC system. Once the system is in place, the trenches shall be carefully backfilled with similar material and hand tamped in 6" layers until a minimum of 12" above the top of the preinsulated pipe has been achieved. The remainder of the backfill shall be void of rocks, frozen earth and foreign material. The trench shall be compacted to comply with H-20 Highway loading.

Accessories:

- Heat Tracing

Tricon Piping Systems, Inc.
P.O. Box 361
Canastota, NY 13032

Tel: 315-697-8787
Fax: 315-697-8788
www.triconpiping.com

System Options:

- Contact your Tricon representative for available sizes and system options.
- * Optional metallic casings for above ground applications include, Spiral Lockseam in Galvanized, Aluminum or Stainless Steel.
- * Optional non-metallic casings for below grade offered include, Filament Wound FRP.

Tricon Piping Systems, Inc.
P.O. Box 361
Canastota, NY 13032

Tel: 315-697-8787
Fax: 315-697-8788
www.triconpiping.com

System Options:

- Contact your Tricon representative for available sizes and system options.
- * Optional metallic casings for above ground applications include, Spiral Lockseam in Galvanized, Aluminum or Stainless Steel.
- * Optional non-metallic casings for below grade offered include, Filament Wound FRP.

Tricon Piping Systems, Inc.
P.O. Box 361
Canastota, NY 13032

Tel: 315-697-8787
Fax: 315-697-8788
www.triconpiping.com

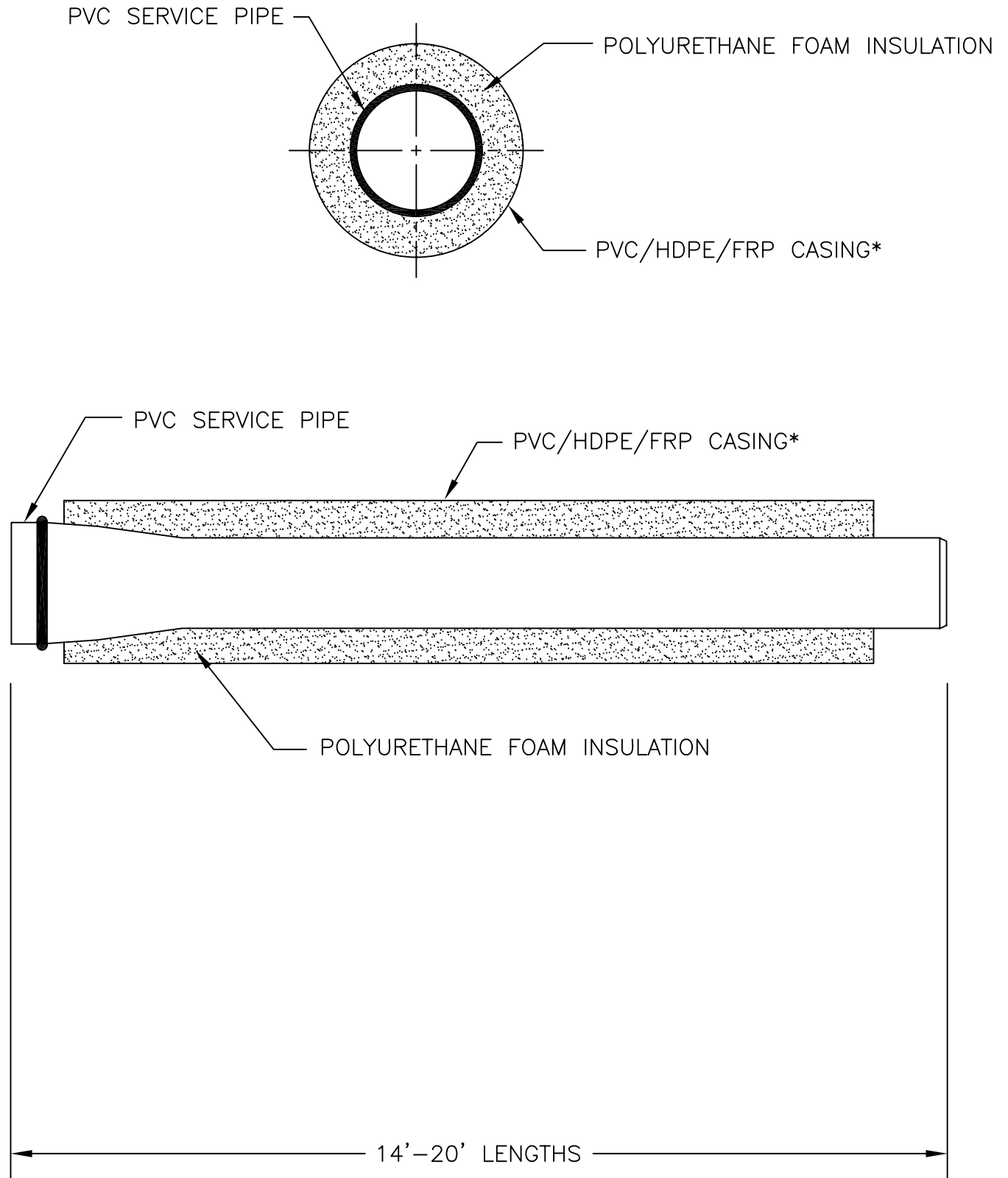

* OPTIONAL METAL JACKET AVAILABLE FOR ABOVE GRADE APPLICATION.

PVC STRAIGHT LENGTH DETAIL — BELL x PLAIN END



TRICON

Piping Systems, Inc. ®

TRICON PVC

Date: 03/09/06

Dwg. No. PVC-1A

Rev.:

P.O. Box 361, Canastota, New York 13032
Tel: 315.697.8787 Fax: 315.697.8788

SCH. 40/80 PVC
SOLVENT WELD
SERVICE PIPE

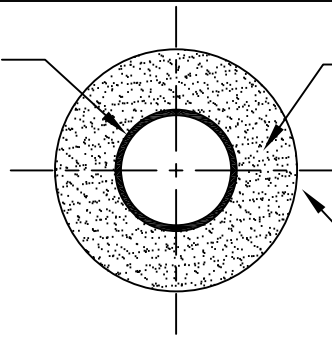

POLYURETHANE FOAM INSULATION

PVC/HDPE/FRP CASING*

END VIEW
NOT TO SCALE

SCH. 40/80 PVC SOLVENT WELD SERVICE PIPE

PVC/HDPE/FRP CASING*

6"

POLYURETHANE FOAM INSULATION

MASTIC END SEAL (TYP.)

20' LENGTHS

* OPTIONAL METAL JACKET AVAILABLE FOR ABOVE GRADE APPLICATION.

PVC SOLVENT JOINT STRAIGHT LENGTH DETAIL

TRICON PVC

Date: 03/09/06 Dwg. No.:PVC-1B

Rev.:



TRICON

Piping Systems, Inc.®

P.O. Box 361, Canastota, New York 13032
Tel: 315.697.8787 Fax: 315.697.8788

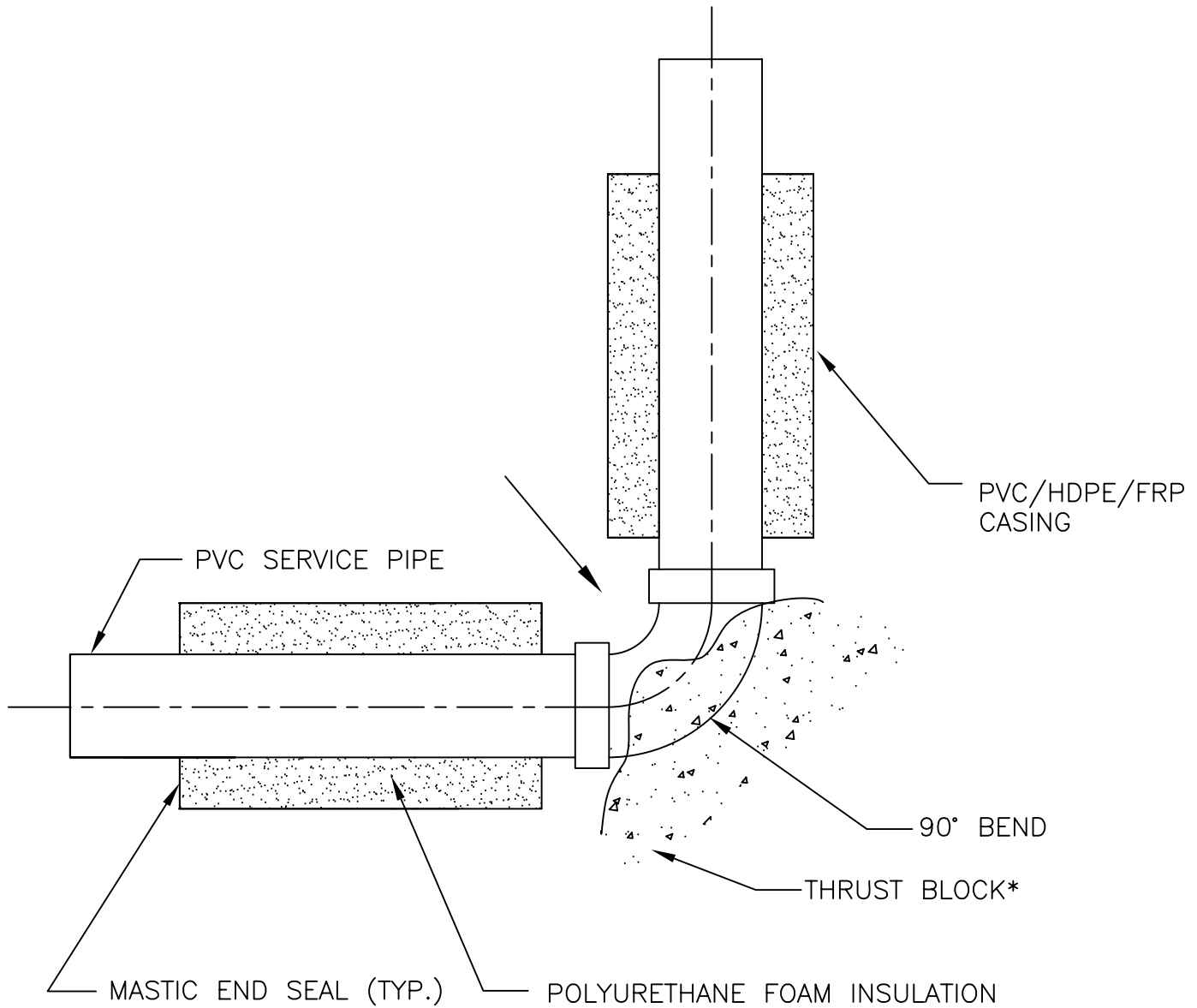
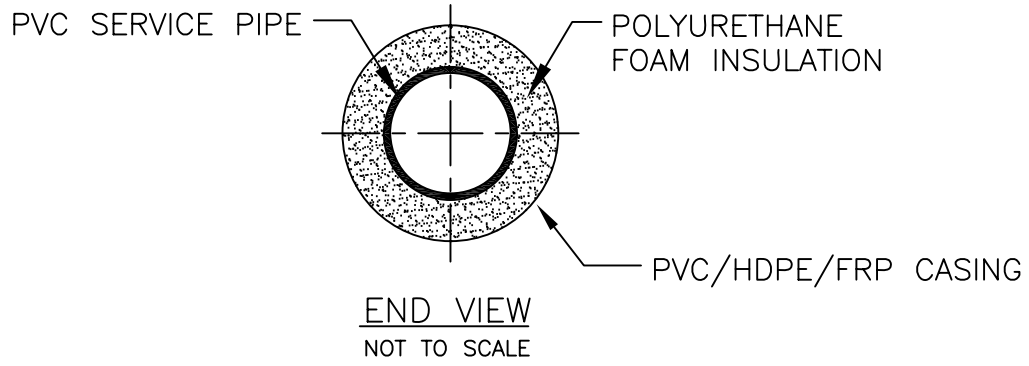

* THRUST BLOCKING IS REQUIRED FOR GASKETED SYSTEMS
CONTACT DESIGN ENGINEER FOR THRUST BLOCK DESIGN,
SIZING AND SOIL CONDITIONS.

PVC 90° ELBOW DETAIL

TRICON PVC

Date: 03/09/06

Dwg. No.: PVC-2

Rev.:



TRICON

Piping Systems, Inc. ®

P.O. Box 361, Canastota, New York 13032
Tel: 315.697.8787 Fax: 315.697.8788

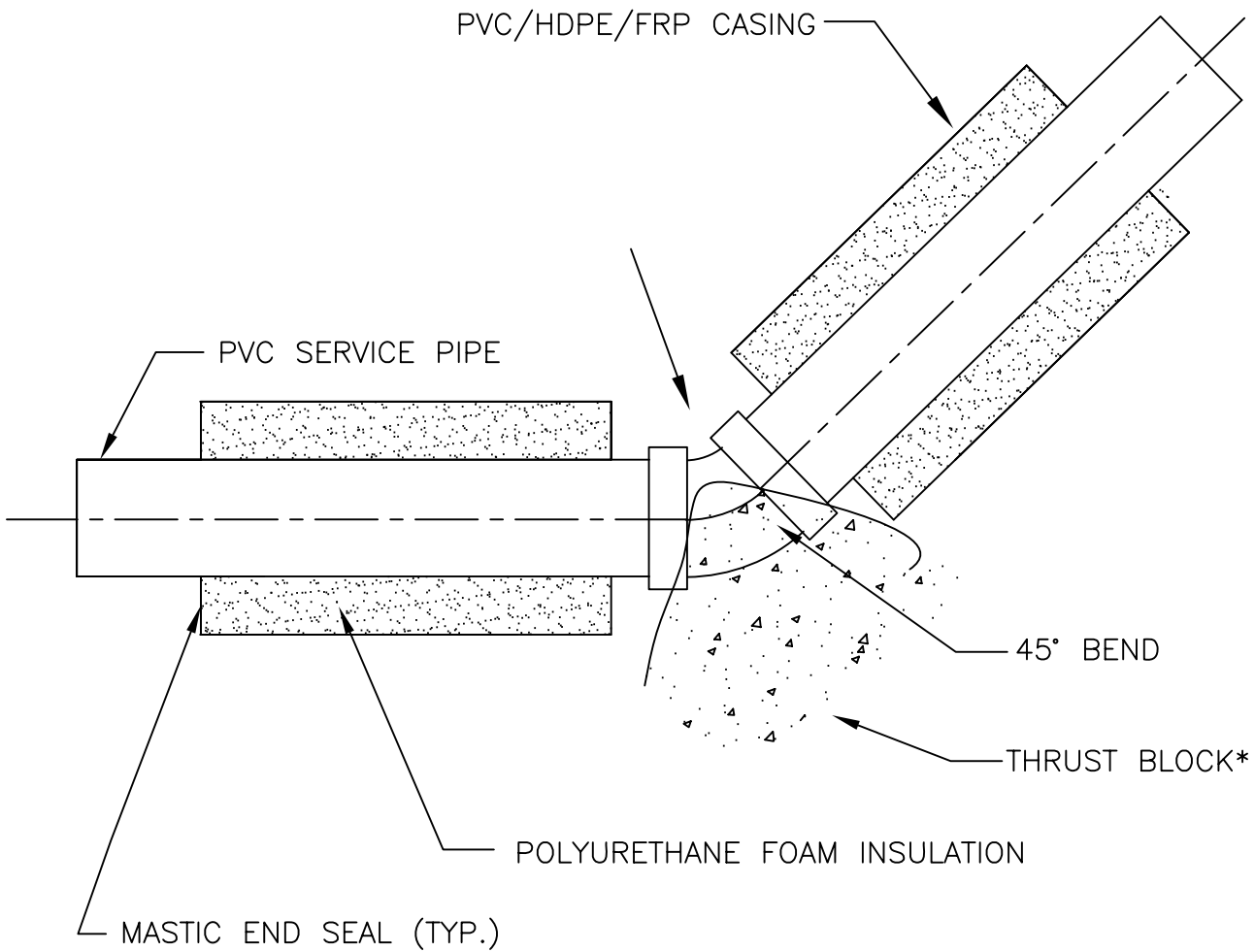
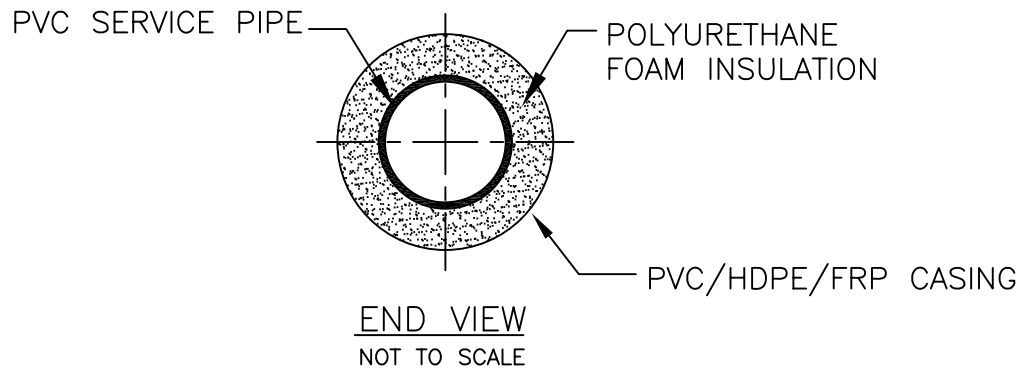

* THRUST BLOCKING IS REQUIRED FOR GASKETED SYSTEMS
CONTACT DESIGN ENGINEER FOR THRUST BLOCK DESIGN,
SIZING AND SOIL CONDITIONS.

PVC 45° ELBOW DETAIL

TRICON PVC

Date: 03/09/06

Dwg. No.: PVC-3

Rev.:



TRICON

Piping Systems, Inc. ®

P.O. Box 361, Canastota, New York 13032
Tel: 315.697.8787 Fax: 315.697.8788

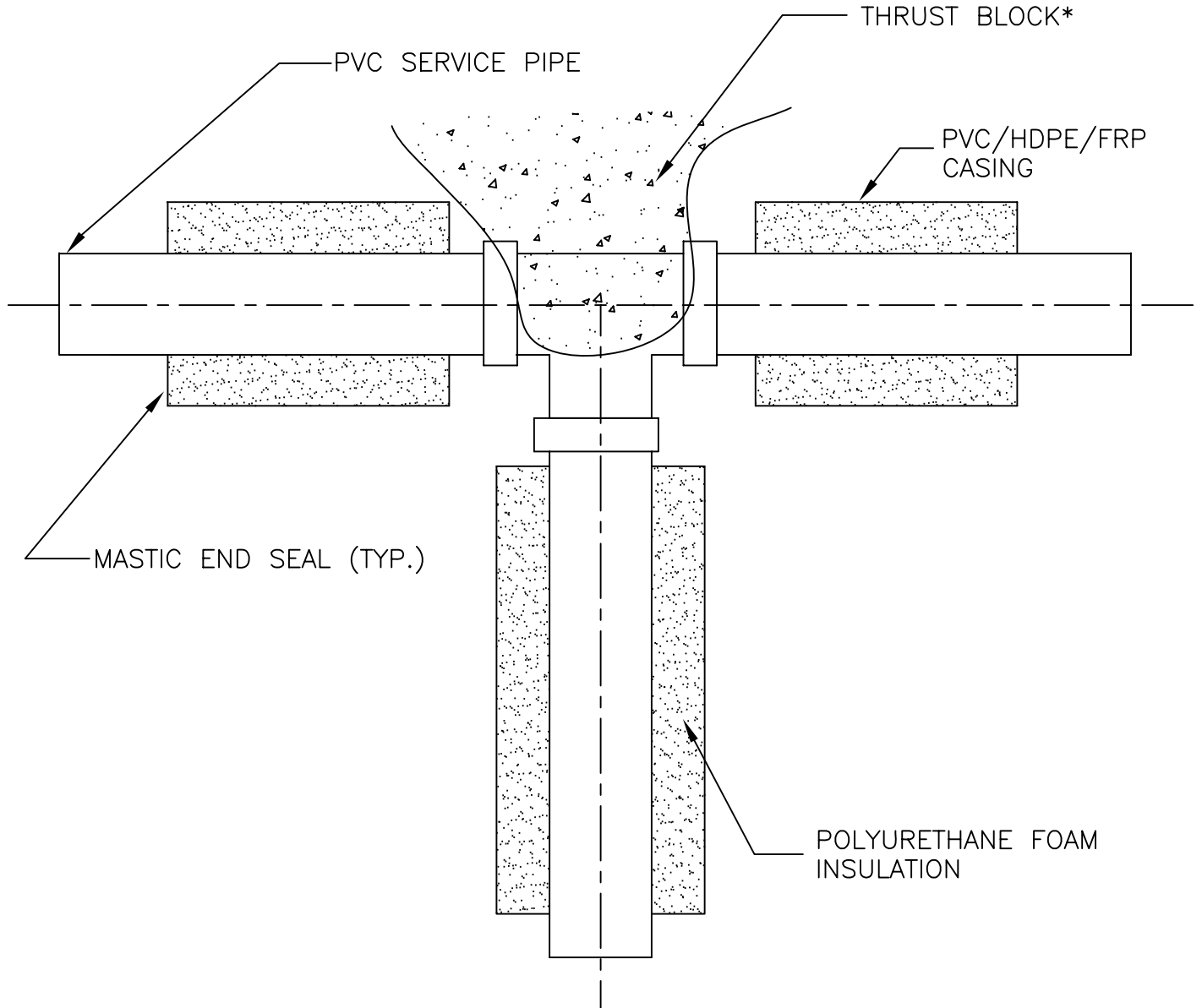
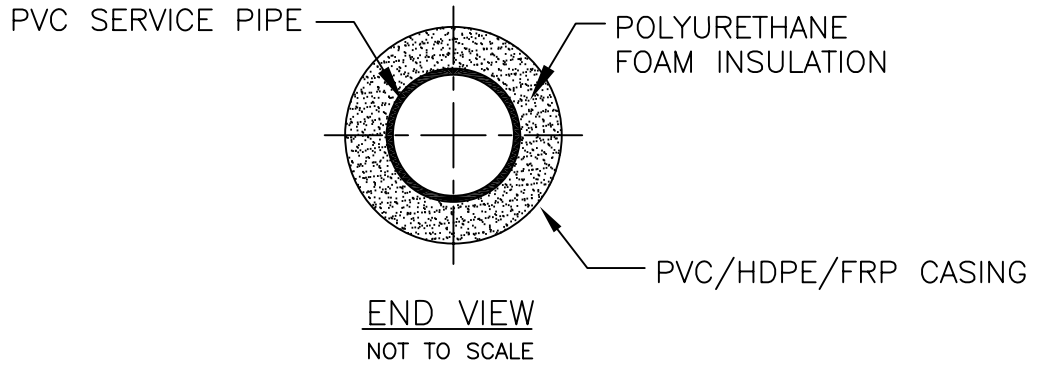

* THRUST BLOCKING IS REQUIRED FOR GASKETED SYSTEMS
CONTACT DESIGN ENGINEER FOR THRUST BLOCK DESIGN,
SIZING AND SOIL CONDITIONS.

PVC TEE DETAIL

TRICON PVC

Date: 03/09/06

Dwg. No.: PVC-4

Rev.:



TRICON

Piping Systems, Inc. ®

P.O. Box 361, Canastota, New York 13032
Tel: 315.697.8787 Fax: 315.697.8788

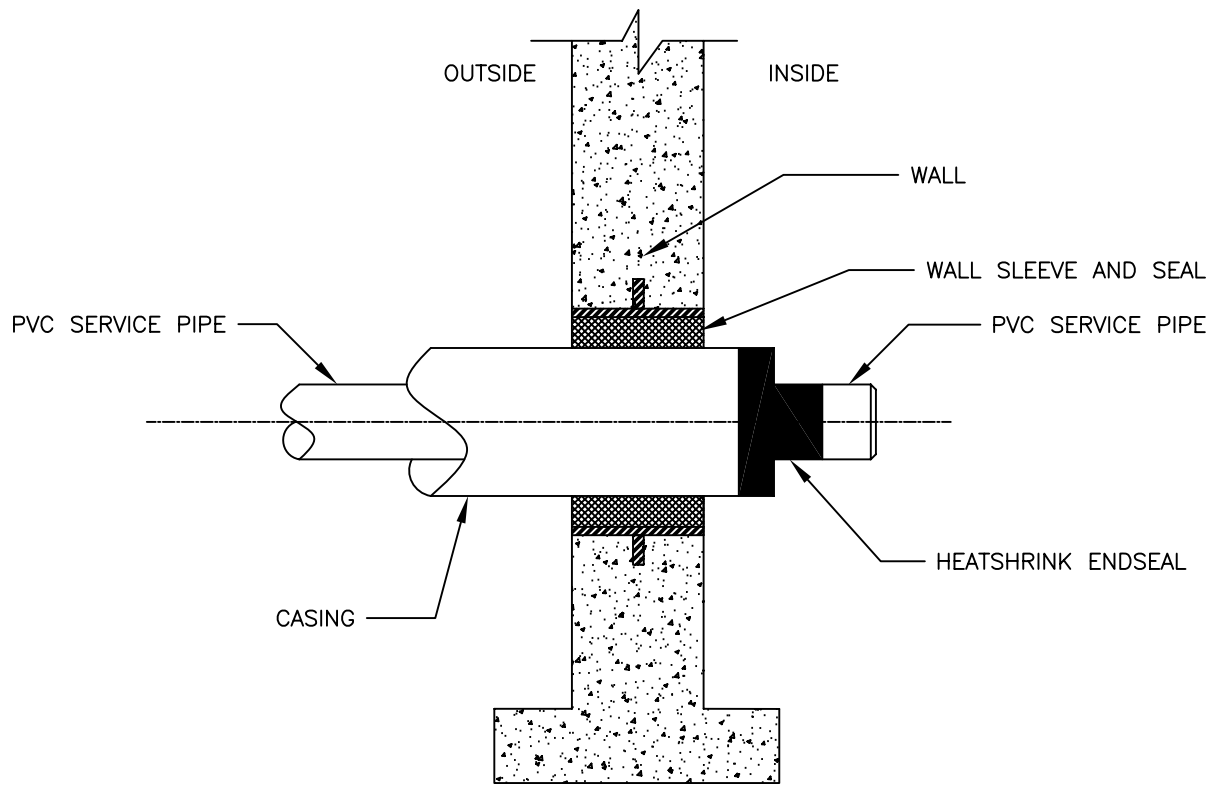

WALL PENETRATION DETAIL

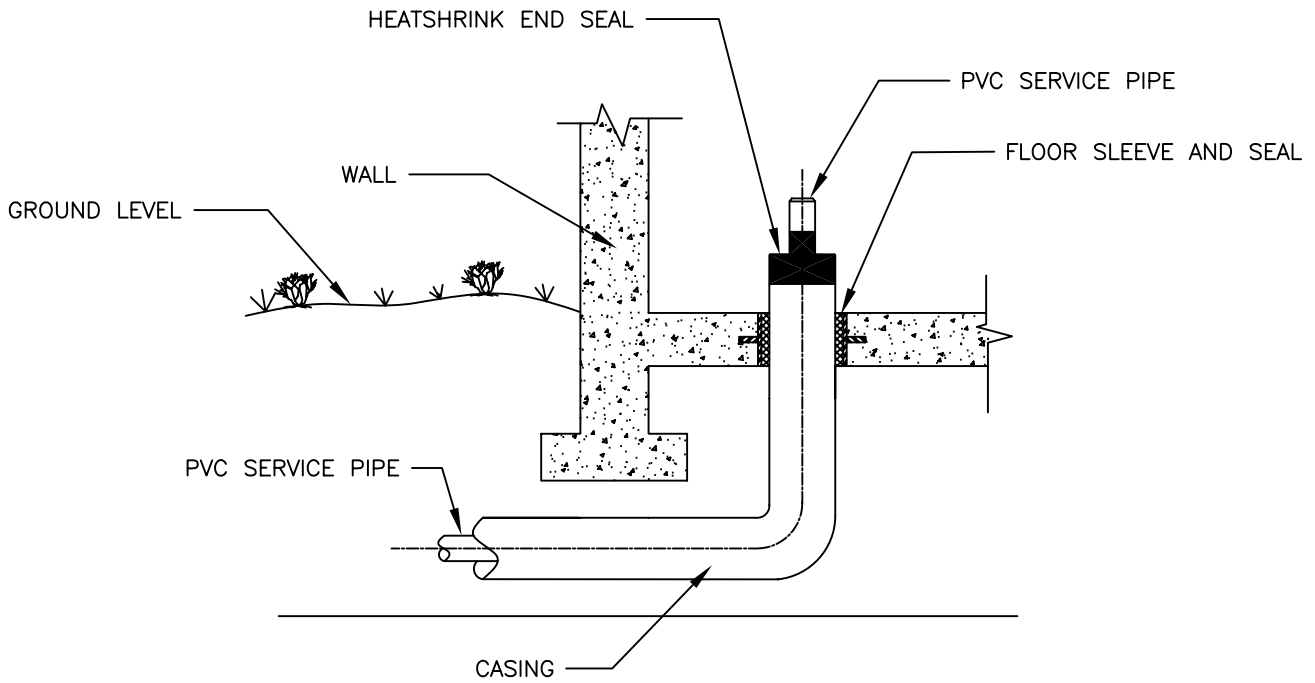

BUILDING RISER DETAIL

HEATSHRINK END SEAL DETAIL

TRICON PVC

Date: 03/09/06

Dwg. No.: PVC-5

Rev.:



TRICON

Piping Systems, Inc.®

P.O. Box 361, Canastota, New York 13032
Tel: 315.697.8787 Fax: 315.697.8788

PHASE 1

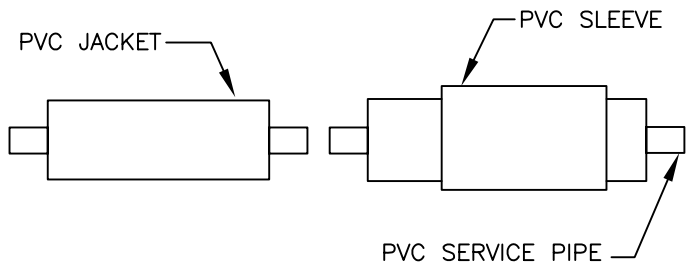

SLIDE PVC SLEEVE OVER PIPE BEFORE GLUING TOGETHER.

CHECK DRY FIT OF PIPE AND COUPLING. PIPE SHOULD ENTER AT LEAST 1/3 THE WAY WITHOUT FORCING. IF TOO TIGHT, FILE OR SAND PIPE TO PROPER FIT.

USE PVC PRIMER TO REMOVE SURFACE GLOSS FROM PIPE END AND INSIDE COUPLING.

PHASE 2

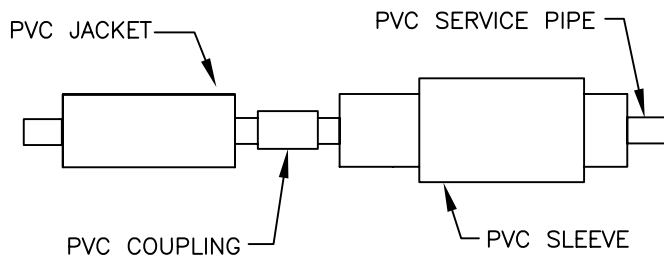

APPLY AN EVEN LAYER OF CEMENT INSIDE COUPLING AND PIPE EQUAL TO SOCKET DEPTH.

WHILE CEMENT IS STILL WET, INSERT PIPE INTO COUPLING WITH 1/4 TURN TWISTING MOTION UNTIL IT BOTTOMS INTO SOCKET.

HOLD JOINT TOGETHER FOR AT LEAST 30 SECONDS

WIPE OFF EXCESS. ALLOW 15 MINS BEFORE HANDLING. WAIT 24 HRS TO APPLY FULL LINE PRESSURE.

PHASE 3

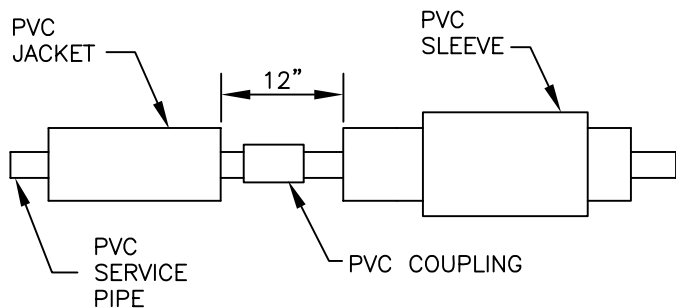

AFTER ALL PVC COUPLING ARE GLUED TEST ALL JOINTS AS REQUIRED.

DO NOT TEST WITH AIR OR GAS

PHASE 4

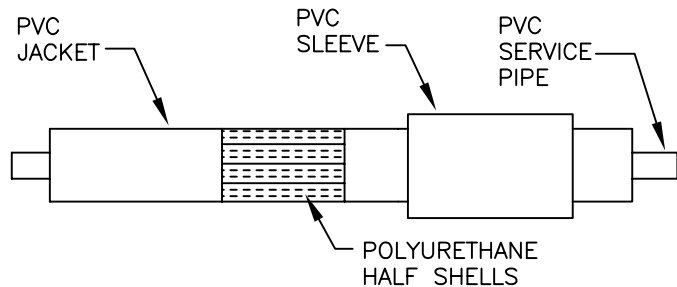

FIT POLYURETHANE FOAM HALF SHELLS OVER SERVICE PIPE AND SECURE IN PLACE.

PHASE 5

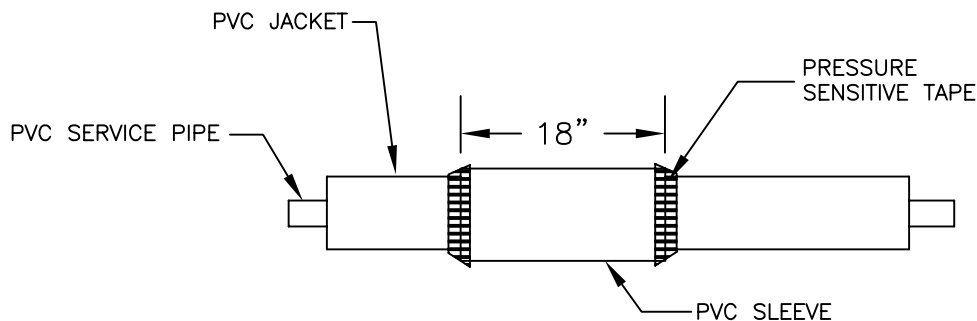

SLIDE PVC SLEEVE INTO CENTER OF JOINT OVER INSULATION. APPLY A WRAP OF PRESSURE SENSITIVE TAPE AROUND THE AREA WHERE THE CASING AND SLEEVE MEET. ALLOW A 2" OVERLAP OF TAPE ONTO BOTH SURFACES.

IN COLDER WEATHER, TAPE MUST BE KEPT WARM UNTIL TIME OF USE.

PVC SOLVENT WELD FIELD JOINT WITH PVC JACKET

TRICON PVC

Date: 03/09/06

Dwg. No. PVC-6

Rev.:



TRICON
Piping Systems, Inc.®

P.O. Box 361, Canastota, New York 13032
Tel: 315.697.8787 Fax: 315.697.8788

STEP 1

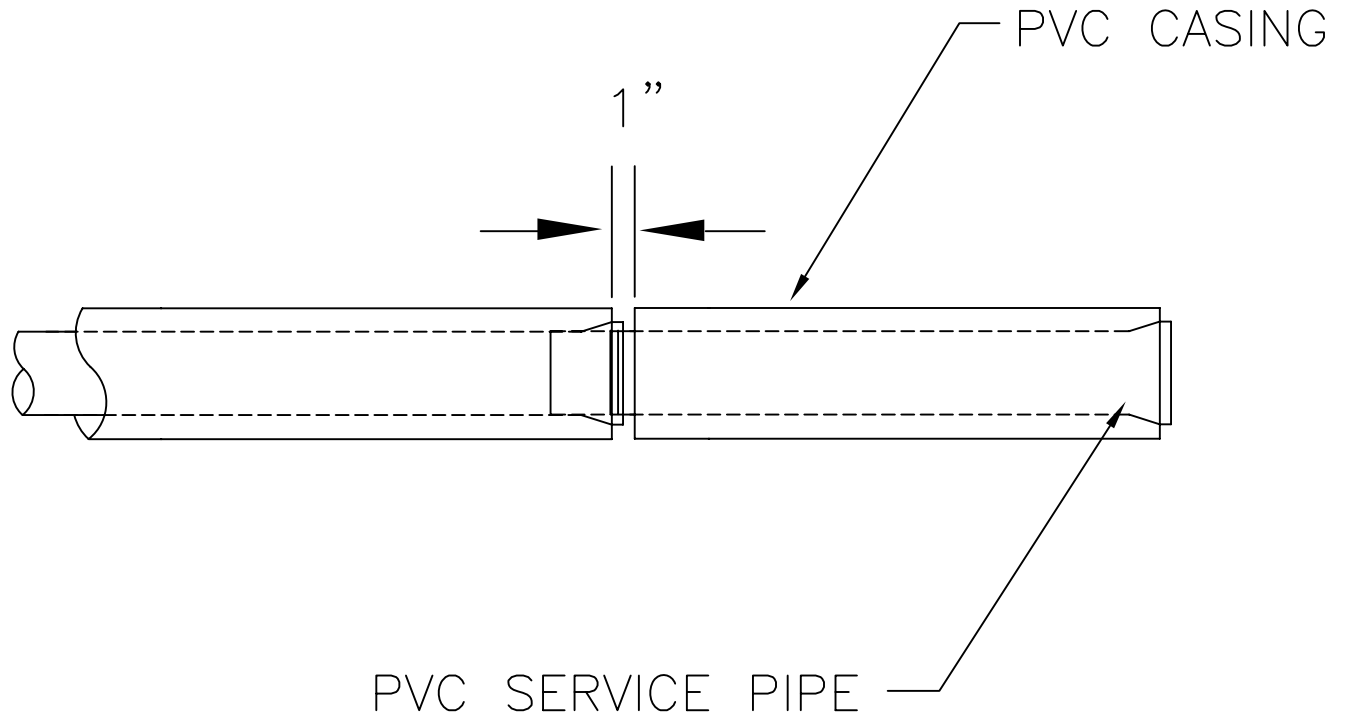

PUSH PIPE TOGETHER UNTIL INSERTION DEPTH IS ACHIEVED
COVER 1" GAP WITH A STRIP OF POLYKEN TAPE.
ENSURE TAPE OVER LAP OF NOT LESS THAN 2".

IN COLDER WEATHER, TAPE MUST BE KEPT WARM UNTIL TIME OF USE

TRICON PVC FIELD JOINT KIT DETAIL

TRICON PVC

Date: 03/09/06

Dwg. No. PVC-7

Rev.:



TRICON

Piping Systems, Inc. ®

P.O. Box 361, Canastota, New York 13032
Tel: 315.697.8787 Fax: 315.697.8788

STEP 1

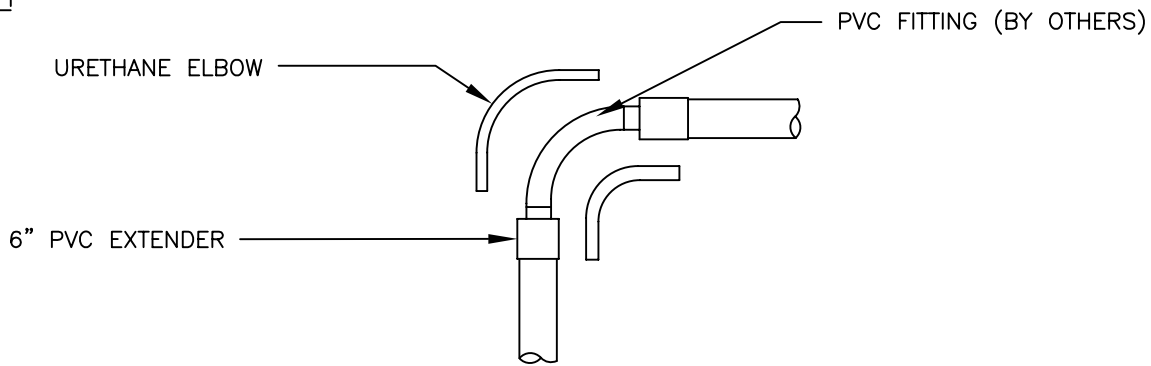

1. SLIDE 6" PVC SLEEVE EXTENDERS ONTO END OF PIPE CASING BEFORE ELBOW IS SOLVENT WELDED.
2. TEST ALL SOLVENT WELD JOINTS AS REQUIRED. **DO NOT TEST WITH AIR OR GAS**
3. FIT POLYURETHANE FOAM INSULATION OVER FITTING AND SECURE IN PLACE.
4. CUT AND FIT STRAIGHT PIPE COVERING INTO PLACE THAT URETHANE ELBOW DOES NOT COVER.
5. SLIDE EXTENDERS IN PLACE AND SECURE WITH POLYKEN TAPE.

STEP 2

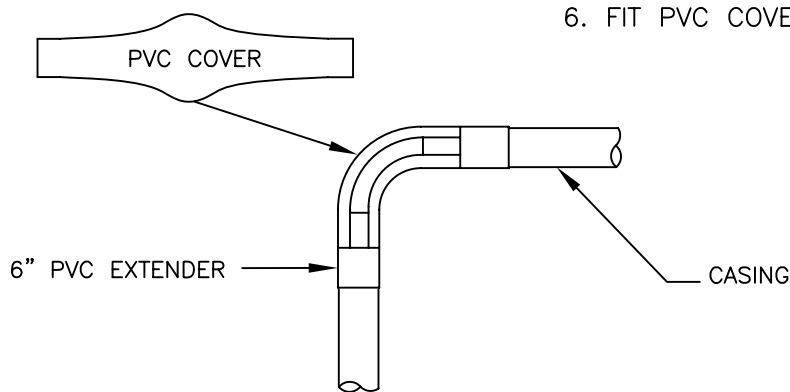

6. FIT PVC COVER OVER FITTING.

STEP 3

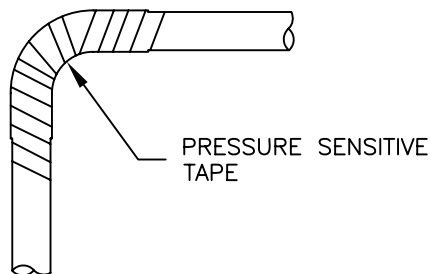

IN COLDER WEATHER, TAPE MUST BE KEPT WARM UNTIL TIME OF USE.

7. WRAP FITTING WITH PRESSURE SENSITIVE TAPE AS SHOWN.

DO NOT TEST WITH AIR OR GAS

TRICON PVC FIELD INSULATED ELBOW FITTING KIT DETAIL WITH RIGID INSULATION.

TRICON PVC

Date: 03/09/06

Dwg. No. PVC-8

Rev.:



TRICON

Piping Systems, Inc.®

P.O. Box 361, Canastota, New York 13032
Tel: 315.697.8787 Fax: 315.697.8788